

Redefine the possible

Markem-Imaje CSAT GmbH

Markem-Imaje CSAT GmbH

Redefine the possible

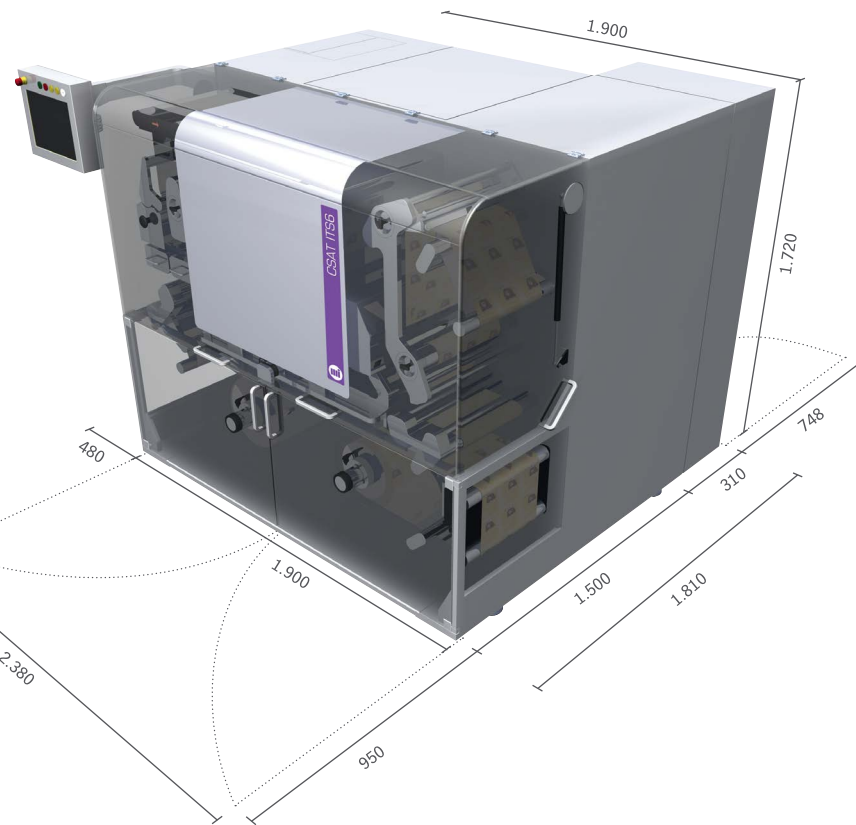

#### Printing unit

Printing	UV DoD inkjet (piezo technology)
Print widths	100/210 mm (3.94/8.27 in)
Colors	4 primary colors (CMYK)
Physical print resolution	600 × 600 dpi
Ink drying	UV LED
Cleaning	Automatic cleaning
Print speed	Max. 48 m/min (157.48 ft/min)

#### Substrates

Material / surface	Continuous or pre-die cut label material made of paper or plastic/ aluminum/ composite foils
Width	220 mm (8.66 in)

#### Operation: Touch panel

Data formats	PDF and TIFF image files are supported
Data management	Job selections and specific settings are entered directly on the touchscreen

#### Dimensions of machine / printing unit (L x W x H)

Print width 100/210 mm (3.94/8.27 in)	1,800 × 985 × 1,640 mm (70.87 × 38.78 × 64.57 in); length with monitor arm: 2,280 mm (89.76 in)
---------------------------------------	---

#### Options

- Color line scan camera to check images, bar codes and text
- Corona treatment
- Antistatic bars (winding and unwinding sides)
- Optional rewinder and unwinder
- Digital front end (DFE) incl. workflow and color management

#### Modular. Dynamic. Efficient.

From imprinting simple bar codes to full-area printing of high-quality labels. CSAT ITS6 prints the widest possible range of materials. Its print quality sets new standards in DoD inkjet printing and its speed easily matches that of surrounding production processes.

CSAT ITS6 combines the benefits of digital printing – such as flexibility, variability, as well as the option of integrating into existing production and process controls – with excellent cost-efficiencies for short and medium runs.

The particular strengths of CSAT ITS6 include its straightforward and reliable operation. Most maintenance processes – such as cleaning print heads – are fully automatic. The machine is fully encapsulated and meets even the strict quality assurance standards of the pharmaceuticals industry.

Experience and innovation. CSAT ITS6 printing systems benefit from the experience of Markem-Imaje CSAT, its understanding of the true meaning of quality, and the innovative energy of the company's fledgling digital division. When developing its printing systems, Markem-Imaje CSAT makes a point of entering into close dialog with users from an early stage. This delivers adaptable digital printing systems that are ideally equipped for the markets' long-term requirements.

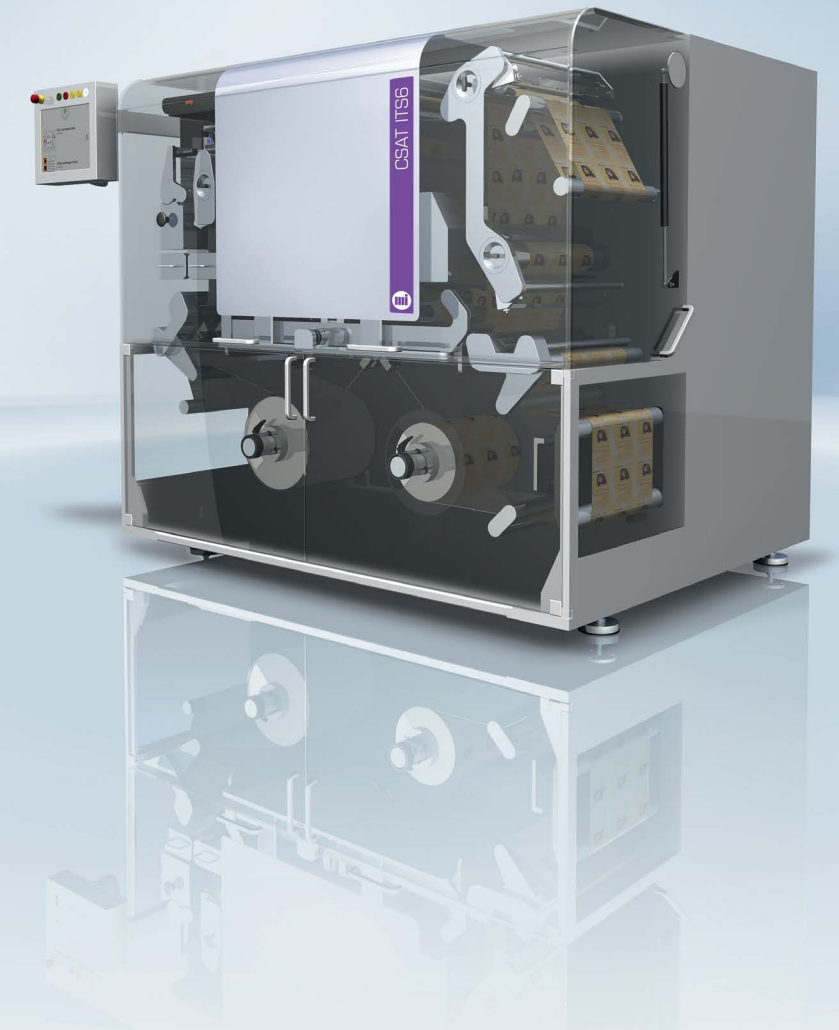

# CSAT ITS6

CSAT ITS6

The Plus Points of CSAT ITS6 – for Your Benefit.



markem·imaje

a DOVER company

## Markem-Imaje CSAT GmbH

Redefine the possible

1

### High resolution and speed

- Physical resolution in CMYK: 600 x 600 dpi
- Print speed up to 48 m/min (157.48 ft/min)

2

### Coordinated with the substrate

- Substrate-optimized inks for versatile direct printing
- Easy ink changes without interrupting printing
- Integrated surface optimization: Web cleaning (standard) and Corona (optional) and Corona (optional) Pin / Final Curing via UV LED

3

### Optimized processes

- Start/stop technology: Printing with no gaps or material losses
- Encapsulated machine for added safety and protection against dust
- 100% print monitoring (optional)

4

### Easy operation

- Straightforward operation thanks to large touchscreen
- Automatic cleaning of print heads

5

### Compact and powerful

- Small footprint: 1.90 m x 1.81 m (74.80 in x 71.26 in)
- Reel diameter: 600 mm (23.62 in) with larger option available

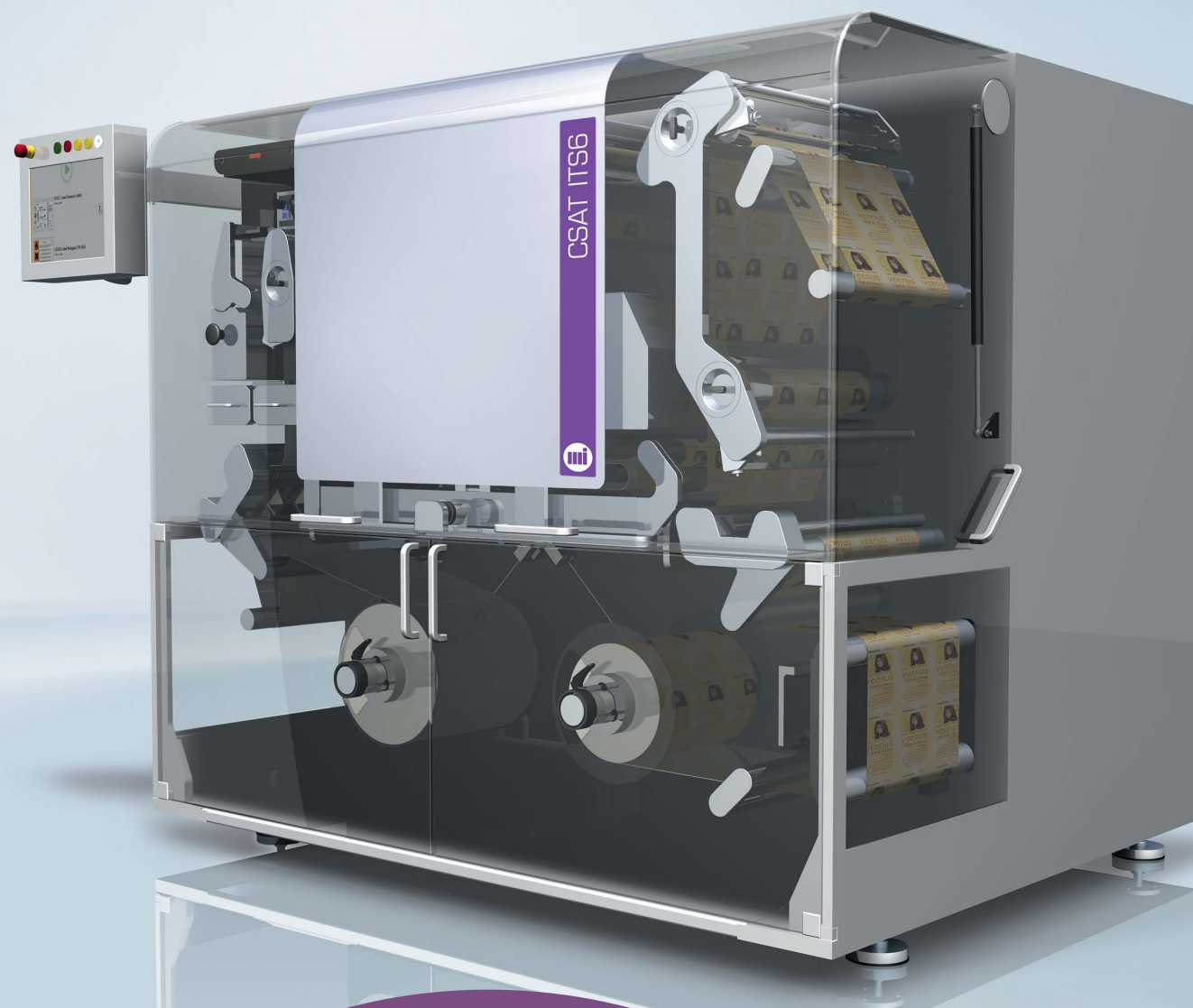

### A Matter of Principle: Cooperative, Transparent

CSAT ITS6 is series produced, but each system is also made to measure and individually equipped for its specific use. When configuring your CSAT system, we work closely with you and take into account your specific printing system requirements. As a result, you get exactly what you need – nothing more, nothing less, and nothing different.

If needed, Markem-Imaje CSAT can also develop an appropriate workflow solution for you and, if necessary, integrate it into your production process. The same applies to connecting the press to your production line. Markem-Imaje CSAT modular portfolio covers everything from equipping your machine and integrating it into your production environment to a full range of services.

We focus on ensuring transparency and dialog with our customers. As a result, you know from the outset which services you need or are useful and which are not. You have a complete overview of all the options and can weigh up the best cost-benefit ratio for your company. You decide which equipment and services to choose.

### The Printing System

CSAT ITS6 is a flexible all-rounder that prints all the usual label materials along with a number of more unusual ones – from paper and plastic/ metal foils to specific material combinations. It also processes substrates that are pre-printed, coated, or have other kind of surface finishing.

The standard configuration of CSAT ITS6 systems includes web cleaning to optimize the surfaces to be printed. If

appropriate for the printing materials a company intends to use, Corona pre-treatment can also be integrated to expand the range of materials that can be processed further still.

Premium print results are ensured by the high-performance print heads with advanced DoD UV inkjet technology. Other benefits of CSAT ITS6 include contactless printing and LED UV pin and final curing process. Intermediate drying adds to the already consistently high quality of the print images.

The UV inks used are perfectly coordinated with the material to be printed and the intended use of the labels, which ensures a visually perfect and durable print image for numerous applications.

The printing system is either supplied as a standalone machine or can be connected directly to the production line – depending on the most expedient and efficient solution for your workflows.

A large touchscreen is used to operate the printing system and manage the print lists. Its clearly arranged user interface ensures straightforward, user-friendly operation.

All CSAT ITS6 systems benefit from powerful control software that makes for easy print job management and can be incorporated into your company's ERP system in whole or in part.

CSAT ITS6 meets the highest quality standards. The printing system is designed in line with the latest GAMP, cGMP, and FDA regulations, which also makes it suitable for chemical and pharmaceutical applications.

**CSAT ITS6 optimizes your production and packaging processes.**